



Convection experiments in a centrifuge and the generation of plumes in a very viscous fluid

H.-C. NATAF (*), B. H. HAGER

*Seismological Laboratory, 252-21, California Institute
of Technology, Pasadena, California, 91125, U.S.A.*

and

R. F. SCOTT

*Department of Engineering and Applied Sciences, California Institute
of Technology, Pasadena, California, 91125, U.S.A.*

Received 07/08/83, accepted 19/12/83.

ABSTRACT. « Plumes » originating from unstable thermal boundary layers have been proposed to be the preferred mode of small-scale convection in the Earth's mantle. However, doubts have been cast on the validity of the extrapolation from laboratory to mantle-like conditions. In particular, it was feared that inertial effects might be the origin of the observed instabilities.

In this paper, experiments are described for which inertial effects are negligible. A small aspect-ratio tank filled with a very viscous fluid ($Pr = 10^6$) is used to observe the behaviour of convection for Rayleigh numbers up to 6.3×10^5 . These high values are reached by conducting the experiment in a centrifuge which provides a 130-fold increase in apparent gravity. Rotational effects are small, but cannot be totally dismissed. In this geometry thermal boundary layer instabilities are indeed observed, and are found to be very similar to their lower Prandtl number counterparts. It is tentatively concluded that once given a certain degree of « vulnerability », convection can develop « plume »-like instabilities, even when the Prandtl number is infinite. The concept is applied to the earth's mantle and it is speculated that « plumes » could well be the dominant mode of small-scale convection under the lithospheric plates.

Key words : convection currents, instruments and techniques.

Annales Geophysicae, 1984, 2, 3, 303-310.

1. INTRODUCTION

Since the early days of plate tectonics, the possibility of having two scales of convective motions in the mantle has been recognized (Richter, 1973*b*). Large-scale motions are seen in the spreading of the ocean floor, which is responsible for most of the heat loss of the earth's mantle. Smaller-scale convective motions under the tectonic plates are not directly seen but are required in order to explain the observed flattening of the oceanic floor (Parsons and Sclater, 1977) and of the geoid (Crough, 1979) with age. Simple analyses show that the upper thermal boundary layer associated with the large-scale circulation alone becomes unstable long before the oceanic plate founders back into the mantle (Parsons and McKenzie, 1978). This result is confirmed when more realistic rheologies are chosen (Claude Jaupart, personal communication, 1981; Yuen and Fleitout, 1984). Small-scale convection beneath the plates thus seems both needed and possible.

The shape it assumes remains, however, largely uncertain. Two models have been proposed : in the first

one, secondary convection is described as « plumes » rising from the lower thermal boundary layer of the large-scale circulation (Morgan, 1971; Heestand and Crough, 1981). When the « plumes » reach the surface, they form the « hot spot » volcanic chains and swells (such as Hawaii). In the second model, convection rolls with axes aligned in the large-scale spreading direction are the preferred mode of secondary convection under the plates (Richter, 1973*b*). Attempts to « see » through the plates by using correlations between surface gravity and topography show that secondary convection is present (McKenzie *et al.*, 1980). However, the data do not at present differentiate between the two proposed models.

It is therefore necessary to discuss the problem of small-scale convection on theoretical grounds. This is a difficult task for several reasons :

1. the geometry of secondary convection is largely controlled by its interaction with the large-scale circulation ;
2. the problem is intrinsically 3-dimensional, and often time-dependent ;
3. the equations governing high Rayleigh number convection are strongly non-linear. Not all mathemati-

(*) Now at : Laboratoire de Géophysique et Géodynamique Interne, Bâtiment 510, Université Paris-Sud, 91405 Orsay Cedex, France.

cal solutions are physically stable. All physical solutions are not « geophysically stable ». But the number of geophysically realizable solutions is still enormous;

4. even in simple geometries, the occurrence of secondary convection and the shape it assumes are intensely debated topics among hydrodynamicists.

Because of point 2, 2-dimensional numerical studies are of limited interest for this problem, although they can bring some insight to its study (Houseman, 1983). Therefore, attention has focused primarily on experimental work. Two aspects of the interaction between the large-scale circulation and secondary motions have been studied so far. The first study (Richter and Parsons, 1975) showed that the mechanical drag exerted by a moving plate on convection underneath favors small-scale convection rolls with axes aligned in the plate velocity direction, at least when the plate is moving fast enough. In the second study (Nataf *et al.*, 1981), a large-scale circulation was set by cooling on a side, a condition that models the thermal effect of a subducted oceanic plate on subcontinental convection (Rabinowicz *et al.*, 1980). In that case, localized « plumes » form regularly in the thermal boundary layers of the large-scale roll and are swept away in its circulation, when the Rayleigh number is large enough. Both the mechanical and the thermal effects of the large-scale circulation are present in the earth's mantle (Houseman, 1983). The first one might be dominant in the middle of large plates, while the second one might prevail in the vicinity of subduction zones. Therefore, both modes of small-scale convection — rolls and « plumes », and possible intermediate forms — might be present in the mantle beneath the plates. More refined experiments, including both thermal and mechanical effects, are necessary in order to assess more precisely the existence domain of each process.

The goal of the experiments described in this paper is much more limited : it is to bring additional elements to the present debate around the occurrence of secondary convection *via* « plume » instabilities in a simple geometry (point 4 above). It is indeed necessary to better understand the physics of this phenomenon before discussing its possible role within the earth. In particular, one has to check that inertial effects are not responsible for the generation of the « plumes » observed in the laboratory. We study 3-dimensional convection cells in a small aspect-ratio tank. A very viscous fluid is used (Prandtl number of 10^6) and « plumes » are observed for a Rayleigh number of 6.3×10^5 . High Prandtl and Rayleigh numbers are obtained by placing the experiment in a centrifuge, which provides a 130-fold increase in the effective gravity. This technique could help extend the present experimental possibilities in convection.

In the next section we detail the motivation for this study, set the physical frame for its discussion and describe the experimental set-up. Results are presented in section 3 and compared to earlier experimental results. A discussion follows that focuses on the relation of laboratory experiments to mantle convection, on the basis of a new tentative concept : the « vulnerability » of convection to plume-like instabilities.

2. PHYSICAL BACKGROUND AND EXPERIMENTAL CONDITIONS

Time-dependent « plumes » have been observed in fully developed convection cells in large aspect-ratio tanks by Krishnamurti (1970, 1973). For several reasons that will be discussed later her experiments must be interpreted with some care. More recently, small-scale convection taking the form of time-dependent « plumes » has been described in some detail by Bergé and Dubois (1979) and Dubois and Bergé (1981) for experiments in a small aspect-ratio tank. The lateral walls help stabilize the 3-dimensional convection pattern while they somewhat destabilize the boundary layers associated with it. This results in the generation of « plumes » that can be easily followed and studied. The interest of these experiments for geophysics is that they could help place bounds on the « vulnerability » of a given 3-dimensional convection pattern to the generation of « plume » instabilities.

The dimensions of the tank used by Dubois and Bergé (1981) are : length/depth = 2, width/depth = 1.2, with a depth of 2 cm. The fluid is a silicon oil with a Prandtl number of 130. They observe a periodic generation of « plumes » for Rayleigh numbers Ra larger than 4.3×10^5 for a particular cell configuration. « Plumes » form in the upper cold boundary layer near the walls and are advected in the larger-scale circulation. The period of formation is about 32 s for $Ra = 5.1 \times 10^5$.

Because the Prandtl number is not so large in their experiments, it appeared necessary to repeat them using a fluid of much higher viscosity, in order to check that inertial effects are not responsible for the observed instabilities. We thus conducted experiments in the same geometry for a very viscous fluid ($Pr = 10^6$) and Rayleigh numbers up to 6.3×10^5 . Figure 1 displays an « exploded » view of the tank. It is filled with a silicon oil of 100000 centistokes viscosity ; other properties are listed in table 1. An interferometric device is used to give fringes of equal gradient of temperature in the fluid (see description in Nataf *et al.*, 1981). Both the tank and the frames of the interferometric plates are designed to withstand a 130 *g* acceleration. Indeed, in order to reach Rayleigh number values up to 6.3×10^5 , gravity is artificially increased by placing the tank on the bucket of a centrifuge. Figure 2 shows the experimental arrangement in the geotechnical centrifuge at the California Institute of Technology (Scott, 1983). Accelerations up to 136 *g* were reached in the fluid for a rotation rate Ω equal to 352 rpm and a radius of 1 m.

We now discuss in more detail the physics behind the experiments to show why we use a centrifuge. The momentum and temperature equations in a rotating convecting fluid in the Boussinesq approximation can be written (from Chandrasekhar, 1961) :

$$\frac{\partial \mathbf{u}}{\partial t} + (\mathbf{u} \cdot \nabla) \mathbf{u} = - 2 \underbrace{\Omega \times \mathbf{u}}_{(2)} + \underbrace{\nu \nabla^2 \mathbf{u}}_{(3)} - \frac{1}{\rho} \nabla P - \alpha (T - T_0) \underbrace{\mathbf{j}}_{(4)}$$

$$\frac{\partial T}{\partial t} + (\mathbf{u} \cdot \nabla) T = \kappa \nabla^2 T$$

Table 1

Fluid properties and experimental parameters.

(a) Dow Corning 200 fluid properties at 25° C as given by the manufacturer

ν	kinematic viscosity	0.1	m ² /s
ρ	density	0.977×10^3	kg/m ³
α	coefficient of thermal expansion	0.96×10^{-3}	K ⁻¹
C_p	specific heat	1.58×10^3	J kg ⁻¹ K ⁻¹
k	thermal conductivity	0.15	W m ⁻¹ K ⁻¹
κ_p	thermal diffusivity	10^{-7}	m ² /s

(b) Experimental parameters

Pr	Prandtl number ($Pr = \nu/\kappa$)	10^6
d	depth of the tank	5 cm
l	width	6 cm
L	length	10 cm
τ	thermal diffusion time	2.5×10^4 s

where \mathbf{u} is the velocity of the fluid in the rotating frame of reference, $\mathbf{\Omega}$ is the rotation vector, T and P are the temperature and pressure, ρ is the density, κ and ν are the thermal diffusivity and kinematic viscosity of the fluid. $\gamma\mathbf{j}$ is the apparent gravity vector resulting from the combined effects of the centrifugal and gravitational potentials (\mathbf{j} remains always perpendicular to the center of the base of the tank in the experiments).

The equations are governed by three dimensionless parameters :

$$\text{Rayleigh number : } Ra = \frac{\gamma\alpha \Delta T d^3}{\kappa\nu};$$

$$\text{Prandtl number : } Pr = \nu/\kappa;$$

$$\text{Taylor number : } Ta = \left(\frac{2\Omega d^2}{\nu}\right)^2;$$

where d is the thickness of the fluid layer and ΔT is the temperature drop across it.

The first thing to show from these numbers is the reason why we choose to use a centrifuge. With ordinary laboratory conditions the only way to get high Rayleigh number convection in a very viscous fluid (i.e. large Prandtl number) is to use a very deep tank. Typically, a depth of about 25 cm is required to reach $Ra = 10^6$ for $Pr = 10^6$. This in turn leads to quite a long thermal diffusion time $\tau = d^2/\kappa$. For a given Rayleigh number, the period of the expected time-dependent instabilities, if they form, is proportional to the thermal diffusion time. For $d = 25$ cm, periods of about 2 hrs are predicted from Dubois and Bergé's results in a smaller tank. These large numbers explain why such experiments have not been performed to date.

An alternative solution that reduces both length and time scales is to increase γ by setting the experiment in a centrifuge. This is a commonly used technique in geotechnical engineering (e.g. Scott, 1983). It has also been successfully applied to the study of gravity tectonics (Ramberg, 1967). It is easily shown that with a 130-fold increase in γ the depth-scale can be reduced to 5 cm, decreasing the period of the expected instabilities to about 5 min.

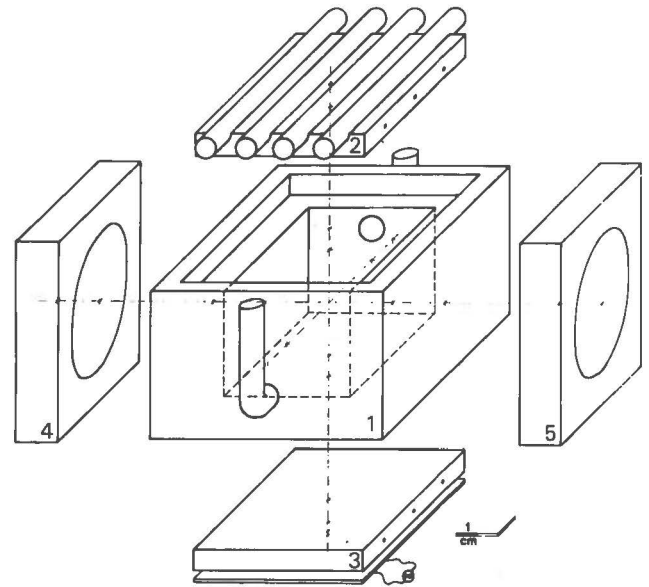

Figure 1

« Exploded » view of the convection tank. The liquid fills a 5 cm (depth) \times 10 cm \times 6 cm volume defined by a 2.5 cm-thick lucite frame (1) sandwiched between two horizontal copper plates. The temperature of the upper plate (2) is set by circulating a thermally regulated liquid through it. Under the bottom plate (3), a flat electric heater is controlled to keep the temperature difference constant between the two plates. This difference is measured with thermocouples, which are low-drift amplified within the centrifuge. The interferometric plates on each side (Françon and Mallick, 1971) are mounted in special frames (4 and 5) so as to withstand the 130 g acceleration to which they are submitted.

Getting back to the momentum equation, we want to assess the importance of the different terms that enter it. In the earth's mantle both inertial (①) and rotational (②) effects are negligible (e.g. Richter, 1973a). The goal of the experiments we describe is to show that even then

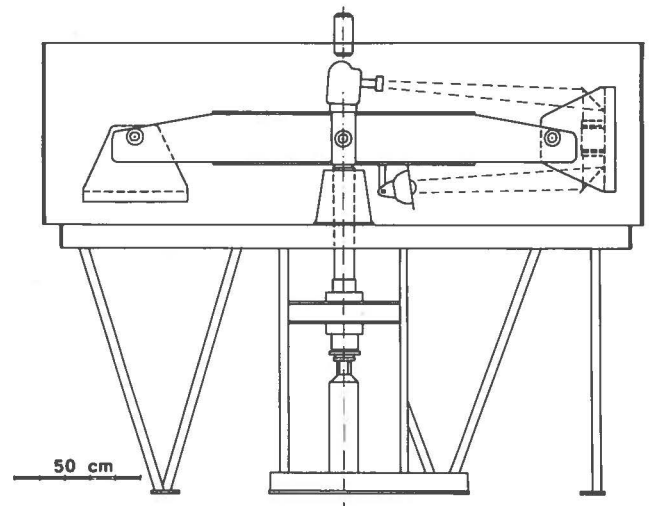

Figure 2

Side-view of the centrifuge set-up. The horizontal arm spins around the central vertical axis at rotational speeds up to 350 rpm. The bucket on the right-hand side is drawn in its flying position while the left one is drawn at rest. The convection tank rests on the bottom of the right-hand side bucket, between two interferometric plates. A mirror sends the interferometric image back to a camera on the center axis. A liquid whose temperature is controlled is used to keep the temperature of the upper plate of the tank constant. The liquid is conducted into the centrifuge through a rotating union at the top. Electric signals are transmitted through a set of slip-rings at the base of the vertical axis. Note the scale of the drawing.

« plume » instabilities can occur (*via* the non-linear terms in the temperature equation). We thus need to evaluate the corresponding terms of the momentum equation for the experiments. We introduce the velocity scale :

$$u = f(Ra) \kappa/d$$

where $f(Ra)$ is found to have a maximum value of about 500 for $Ra = 5 \times 10^5$ in the geometry we discuss (Dubois and Bergé, 1981).

The importance of the advection of linear momentum (inertial effect) is controlled by the Reynolds number Re , which is the ratio of the advection of linear momentum to viscous dissipation :

$$Re = \frac{\textcircled{1}}{\textcircled{3}} = \frac{u^2}{d} \frac{d^2}{\nu u} = \frac{1}{Pr} f(Ra).$$

In Dubois and Bergé's experiments ($Pr = 130$), the Reynolds number is order 1 and inertial effects might play a role. In our experiments ($Pr = 10^6$), this number is decreased to about 10^{-3} and inertial effects are unimportant.

The importance of the advection of angular momentum can be assessed through the ratio of Coriolis forces to buoyancy forces :

$$\frac{\textcircled{2}}{\textcircled{4}} = \frac{2 \Omega u}{\gamma \alpha \Delta T} = \frac{\sqrt{Ta}}{Ra} f(Ra).$$

In our experiments, the Taylor number reaches 3.4 when $\Omega = 352$ rpm, so that this ratio is order 10^{-3} . It thus seems that both inertial and rotational effects are negligible in our experiments, as they are in the earth's mantle.

However, it was pointed out to us by an anonymous reviewer that for internal consistency we needed to compare the advection of angular momentum to viscous dissipation instead. Then :

$$\frac{\textcircled{2}}{\textcircled{3}} = 2 \Omega u \frac{d^2}{\nu u} = \sqrt{Ta}.$$

This number is order 1 in our experiments, whereas it is order 10^{-3} (due to the earth's rotation) in Dubois and Bergé's experiments. It thus appears that what we have gained in the decrease of linear momentum advection is lost in the increase of angular momentum advection, although both terms are likely to be very small in both experiments.

This problem, noticed by the anonymous reviewer, certainly makes our experiment much less demonstrative than we had originally thought. The advection of angular momentum is linear in u . It can't be responsible for time-dependent instabilities with steady-state boundary conditions, whereas the non-linear term describing the advection of linear momentum could trigger such phenomena. It remains true however that the threshold for the appearance of instabilities due to the non-linear terms in the temperature equation could be affected by rotation. Experiments by Rossby (1969) indicate that for

$Ta \simeq 1$ and $Ra \simeq 6 \times 10^5$, rotation has very little effect on global properties of the flow such as heat flux. We thus think that the thermal boundary layer instabilities that we describe in the next section are caused by the non-linear terms in the temperature equation and are typical of high Rayleigh number convection in an infinite Prandtl number fluid enclosed in a small aspect-ratio tank. Possible effects due to rotation cannot be entirely dismissed however.

3. RESULTS

The tank, filled with the $Pr = 10^6$ fluid, was placed in the centrifuge and runs were carried out for Rayleigh numbers of 0.95×10^5 , 5.7×10^5 , and three runs at 6.3×10^5 . In every case the temperatures of the copper plates were set a couple of hours before the centrifuge was started. For the three runs at $Ra = 6.3 \times 10^5$, the temperature contrast across the fluid was 39 °C, yielding a factor of 2 variation in viscosity. The temperature remained stable within ± 0.2 °C during the run while lateral variations within the copper plates amounted to ± 0.3 °C. The centrifuge was spinning at 352.0 ± 0.2 rpm. Because the distance from the axis increases through the depth of the tank, the acceleration had a slight « vertical » gradient in the fluid. A ratio $\rho \Delta\gamma/\gamma \Delta\rho$ of about 2 was typical. It has little effect on convection as it is not advected. On the other hand, there was a lateral variation of about 3 % in γ , which could have some small influence on the convection pattern. This is because we used a tank with plane boundaries instead of having it match the cylindrical equipotential. The centrifuge was run for one hour before photography began; pictures were taken every 15 s over a 20 min period.

While the runs at 0.95×10^5 and 5.7×10^5 appear steady over that period of time, the three runs at $Ra = 6.3 \times 10^5$ all show boundary layer instabilities. These are displayed on figures 3 and 4 where hot « plumes » rise up from the bottom boundary layer near the walls and are swept away into the larger-scale circulation.

Our experiments do not compare in precision nor in wealth of data to the beautiful experiments of Dubois and Bergé (1981), or of Busse and Whitehead (1974) at lower Prandtl number. Therefore at this stage our observations remain rather qualitative. The range of Rayleigh numbers for which we observe boundary layer instabilities is very similar to the range extracted from experiments in fluids with a Prandtl number smaller by several orders of magnitude (Bergé and Dubois, 1979; Krishnamurti, 1970). However, we did not carry out any systematic study on the threshold for the appearance of plumes. This threshold is very much dependent upon the cell structure (Busse and Whitehead, 1974), even in a « small tank » (Dubois, 1982). Because of the difficult experimental conditions in a centrifuge, we could only observe the convection pattern for a limited amount of time. For the runs with $Ra = 6.3 \times 10^5$, 4 to 5 plumes would typically sweep by during the 20 min available for observation. This corresponds to a period of about $10^{-2} \tau$, where $\tau = d^2/\kappa$ is the thermal diffusion time.

Figure 3

Boundary layer instability in a very viscous fluid ($Pr = 10^6$). The centrifuge is spinning at 352 rpm. The acceleration at mid-depth in the tank is 1340 m/s^2 and the Rayleigh number is $Ra = 6.3 \times 10^5$. Time runs from left to right and from top to bottom, with one frame every 15 sec. The pictures represent fringes of equal horizontal gradient of temperature. They show a «plume» (black arrow) originating in the lower thermal boundary layer of the right-hand side convection roll, and being swept into the main circulation marked by a vigorous uprising current in the middle (white arrow), with its characteristic «pair of eyes» signature. The lateral walls of the small tank lie outside the field of view of the interferometric plates, but the full depth of the tank is seen (see fig. 1).

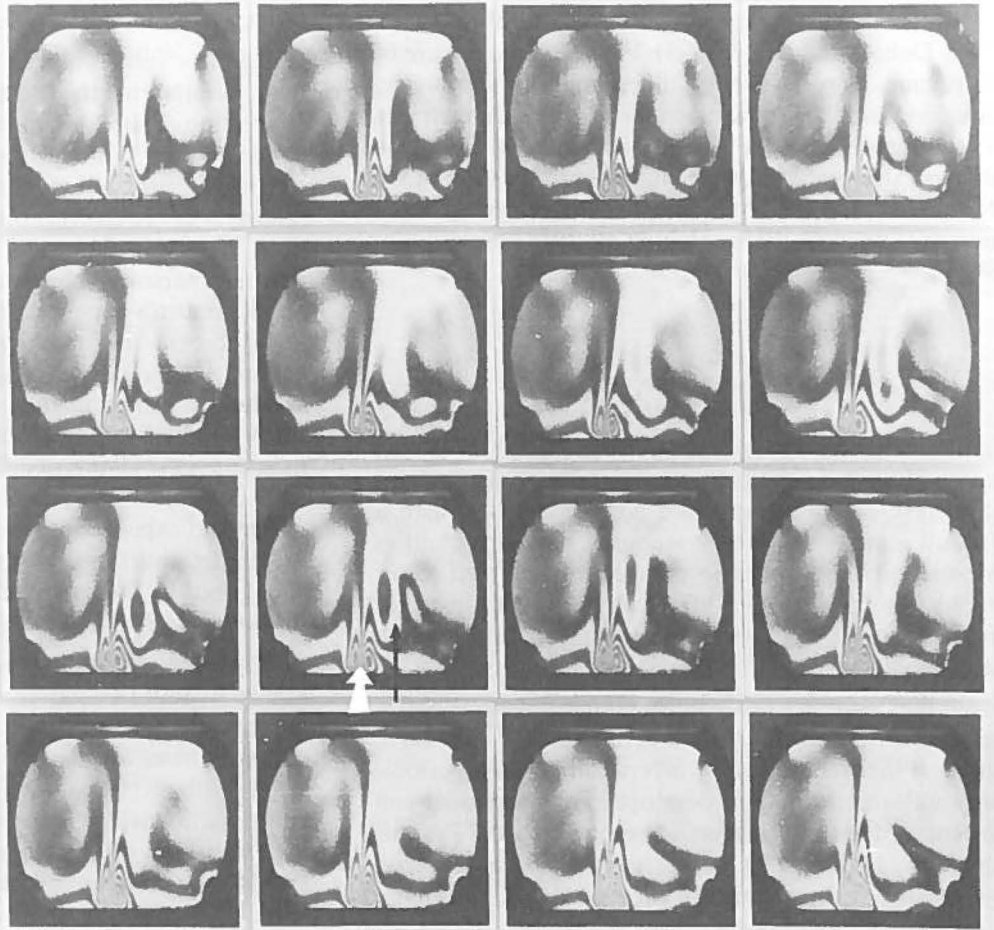

Figure 4

Same as figure 3 but for a different run at the same Rayleigh number. Now the right-hand side of the tank is seen. The downwelling on the right displays a complicated fringe structure due to the presence of the wall of the tank and to the 3-dimensional structure of the flow. The small vertical bars at the top and bottom are markers, 2.5 cm away from the wall. They can also be seen at the edges of the field of view in figure 3. Note that the «plume» (black arrow) originates in the lower boundary layer, close to the wall.



This crude result compares favorably with its lower Prandtl number counterparts (Busse and Whitehead, 1974; Dubois and Bergé, 1981). Finally, the structure of the plumes, as seen through differential interferometry, looks very similar to that seen in the same geometry at lower Prandtl number (Bergé and Dubois, 1979), or observed in elongated convection rolls in the laboratory (Nataf *et al.*, 1981), or in 2-dimensional numerical experiments (Lux *et al.*, 1979; Daly *et al.*, 1982; Houseman, 1983).

4. DISCUSSION

From the results we have presented, conclusions can be drawn along two lines : firstly, boundary layer instabilities have been observed in a convecting fluid with a Prandtl number $Pr = 10^6$; secondly, these instabilities are qualitatively similar to their counterparts at lower Prandtl number ($Pr = 130$). A more precise quantitative comparison remains to be done to further assess the second point.

From the first point we deduce that inertial terms play a negligible role in the formation of this kind of « plumes », and that thermal boundary layers can become periodically unstable in a fully developed 3-dimensional cell structure of natural convection, even when the Prandtl number is infinite. This conclusion has to be tempered by the fact that rotational effects cannot be totally dismissed in our experiment.

From the second point we conclude that the occurrence of thermal boundary layer instabilities and their behaviour observed in experiments on fluids with Prandtl numbers in the range $10^2 - 10^3$ and $Ra \simeq 10^6$ are infinite Prandtl number features. If this is true, we should expect boundary layer instabilities to form when there is cooling on a side (Nataf *et al.*, 1981), or indeed every time an important horizontal temperature gradient is set up (Houseman, 1983) in an infinite Prandtl number fluid.

For further discussions concerning the mode of small-scale convection in the earth's mantle, it seems useful to introduce a concept of « vulnerability ». Under some circumstances, it seems that convection is « vulnerable » to time-dependent boundary layer instabilities. The application of this concept to the earth would rest on estimating the « vulnerability » parameters for the mantle, taking into account the interaction with large-scale lithospheric motions. Experiments such as the one we described can help find the appropriate parameters to describe that phenomenon.

As an example, that concept can be used to clarify the present controversy concerning large Prandtl number convection experiments in large aspect-ratio tanks. Apparently contradictory results have been presented : Krishnamurti (1970, 1973) reports « plume »-like instabilities in a $Pr = 8500$ fluid for Rayleigh number values as low as 5.5×10^4 . On the other hand, Whitehead and Parsons (1978) find no time-dependent feature until $Ra = 1.5 \times 10^5$ for the same Prandtl number. The latter results, together with lower Prandtl number observations by Busse and Whitehead (1974), have been

used to advocate a Prandtl number dependence for the onset of turbulence (Busse, 1981).

Using the « vulnerability » concept, we can try to relate these results and to discuss their relevance to mantle convection. The experiments by Krishnamurti on one hand, and by Whitehead's school on the other hand, differ by several aspects that could bear on the « vulnerability » of the convection cells. Random initial conditions (Busse, 1981), and lateral wall effects (Frank Richter, personal communication, 1983), present in Krishnamurti's experiments can be seen as parameters that increase the « vulnerability » to time-dependent « plumes ». On the other hand, it is maybe decreased in Whitehead's experiments, due to the use of non-perfectly conductive horizontal boundaries. More difficult to assess is the choice of different observational methods to determine the threshold of oscillations. In any case, one would expect convection to be more « vulnerable » in Krishnamurti's experiments than in Whitehead's. This could be the reason for the difference between the reported thresholds to time-dependence.

Our experiments seem to indicate that the occurrence and behaviour of « plume » instabilities for $Ra = 6 \times 10^5$ in a small aspect-ratio tank are similar for Prandtl numbers from 130 to 10^6 . We thus conclude, in agreement with Krishnamurti's results although not in contradiction with Whitehead's findings, that once given a certain level of « vulnerability » (probably caused by the lateral walls in our experiments), « plumes » do form irrespective of the Prandtl number value.

The relevance of the previous discussion to convection in the earth's mantle rests upon the degree of « vulnerability » that can be attributed to the large-scale circulation. There are reasons to believe that this degree is high indeed : large Rayleigh number ($\sim 10^6$), diversity of plate lengths and velocities, important horizontal temperature gradients, and time-dependent plate interactions are all phenomena that could contribute to make the earth's mantle circulation « vulnerable » to time-dependent boundary layer instabilities. That process might therefore be the dominant mode of small-scale convection in the mantle. It is then tempting to relate these « plumes » to the « hot spots » observed at the surface of the plates (Morgan, 1971; Froidevaux and Nataf, 1981; Houseman, 1983), although problems still remain to explain their relative fixity and their isotopic signature.

Nevertheless, the use of a new word cannot replace the understanding of the physics of convection. Further studies are needed to test the validity of the rather vague concept of « vulnerability » that we have introduced, and to help bridge the gap between laboratory experiments and mantle convection.

Acknowledgements

Our thanks go to Don Anderson who made this project come to light. We are thankful to John Lee and John Ting for precious help in running the centrifuge. Bill Barber and Nino Victor provided most valuable technical assistance. The differential interferometer was kindly

given to one of us (HCN) by its inventor, Maurice Françon. We are grateful to Pierre Bergé and Monique Dubois for exciting discussions, and to Frank Richter for helpful criticisms. We acknowledge valuable discussions with D. J. Tritton, and Greg Houseman who also gave us a preprint of his paper. We are indebted to an anonymous

reviewer who made important suggestions and comments that helped put this paper in its present form. This work was supported by the National Aeronautics and Space Administration grant N° NSG-7610. Contribution N° 3953, Division of Geological Sciences, California Institute of Technology, Pasadena, Ca., 91125.

REFERENCES

- Bergé P., Dubois M., 1979. Study of unsteady convection through simultaneous velocity and interferometric measurements, *J. Physique Lettres*, **40**, L-505-L-509.
- Busse F. H., 1981. Transition to turbulence in Rayleigh-Bénard convection, in : Topics in Applied Physics « Hydrodynamic instabilities and the transition to turbulence », Swinney and Gollub, Ed. Springer-Verlag, Berlin, 97-137.
- Busse F.H., Whitehead J. A., 1974. Oscillatory and collective instabilities in large Prandtl number convection, *J. Fluid Mech.*, **66**, 67-79.
- Chandrasekhar S., 1961. Hydrodynamic and hydromagnetic stability. Oxford University Press.
- Crough S. T., 1979. Geoid anomalies across fracture zones and the thickness of the lithosphere, *Earth Planet. Sci. Lett.*, **44**, 224-232.
- Daly S. F., Hager B. H., Raefsky A., 1982. Convection in a large box with heterogeneous velocity boundary conditions : implications for mantle convection (abstract), *EOS*, **63**, 1104.
- Dubois M., 1982. Experimental aspects of the transition to turbulence in Rayleigh-Bénard convection, in Lecture Notes in Physics, Springer.
- Dubois M., Bergé P., 1981. Instabilités de couche limite dans un fluide en convection. Evolution vers la turbulence, *J. Physique*, **42**, 167-174.
- Françon M., Mallick S., 1971. Polarization interferometers; Applications in Microscopy and Macroscopy, J. Wiley, Ed., London, New York.
- Froidevaux C., Nataf H.-C., 1981. Continental drift : what driving mechanism ? *Geologische Rundschau*, **70**, 166-176.
- Heestand R. L., Crough S. T., 1981. The effect of hot spots on the oceanic age-depth relation, *J. Geophys. Res.*, **86**, 6107-6114.
- Houseman G. A., 1983. Large aspect ratio convection cells in the upper mantle, *Geophys. J. Roy. Astr. Soc.*, **75**, 309-334.
- Krishnamurti R., 1970. On the transition to turbulent convection. Part 2. The transition to time-dependent flow, *J. Fluid Mech.*, **42**, 309-320.
- Krishnamurti R., 1973. Some further studies on the transition to turbulent convection, *J. Fluid. Mech.*, **60**, 285-303.
- Lux R. A., Davies G. F., Thomas J. H., 1979. Moving lithospheric plates and mantle convection, *Geophys. J. Roy. Astr. Soc.*, **58**, 209-228.
- McKenzie D. P., Watts A. B., Parsons B., Roufousse M., 1980. Planform of mantle convection beneath the Pacific ocean, *Nature*, **88**, 442-446.
- Morgan W. J., 1971. Convection plumes in the lower mantle, *Nature*, **230**, 42-43.
- Nataf H.-C., Froidevaux C., Levrat J.-L., Rabinowicz M., 1981. Laboratory convection experiments : the effect of lateral cooling and generation of instabilities in the horizontal boundary layers, *J. Geophys. Res.*, **86**, 6143-6154.
- Parsons B., McKenzie D. P., 1978. Mantle convection and the thermal structure of the plates, *J. Geophys. Res.*, **83**, 4485-96.
- Parsons B., Sclater J. G., 1977. An analysis of the variation of ocean floor bathymetry and heat flow with age, *J. Geophys. Res.*, **82**, 803-827.
- Rabinowicz M., Lago B., Froidevaux C., 1980. Thermal transfer between the continental asthenosphere and the oceanic subducting lithosphere : its effect on subcontinental convection, *J. Geophys. Res.*, **85**, 1839-1853.
- Ramberg H., 1967. Gravity, Deformation and the Earth's crust, Academic Press, London.
- Richter F. M., 1973a. Dynamical models for sea floor spreading, *Rev. Geophys. Space Phys.*, **11**, 223-287.
- Richter F. M., 1973b. Convection and the large-scale circulation of the mantle, *J. Geophys. Res.*, **78**, 8735-45.
- Richter F. M., Parsons B., 1975. On the interaction of two scales of convection in the mantle, *J. Geophys. Res.*, **80**, 2529-2541.
- Rosby H. T., 1969. A study of Bénard convection with and without rotation, *J. Fluid Mech.*, **36**, 309-335.
- Scott R. F., 1983. Centrifuge testing at CalTech, *Int. J. Soil Dynamics and Earthquake Engineering*, **2**.
- Whitehead J. A., Parsons B., 1978. Observations of convection at Rayleigh numbers up to 760,000 in a fluid with large Prandtl number, *Geophys. Astrophys. Fluid Dynamics*, **9**, 201-217.
- Yuen D. A., Fleitout L., 1984. Thermomechanical stability of the oceanic lithosphere with highly variable viscosity, submitted to *Phys. Earth Planet. Int.*